

ESL

HFR NUT

ALL METALS – UNC/UNF – BS STANDARD

Definition: reusable slotted self-locking hexagon nut

Threading: series UNC/UNF ASME B1.1 and BS 84 - BSF/BSW on request

Characteristic and performance test: steel ASME B18.16.6 and BS 4929-2

Manufacturing range: metric/inch, all diameters, coarse & fine pitch, special heights & A/F upon request

d/inches	d/mm	Pitch/UNC	Pitch/UNF	s/min.	s/max.	h	m	codes
N°1	1,854	64	72	6,172	6,375	5,30	2,60	B
N°2	2,184	56	64	6,172	6,375	5,30	2,60	C
N°3	2,515	48	56	6,172	6,375	5,30	2,60	D
N°4	2,845	40	48	6,172	6,375	5,30	2,60	E
N°5	3,175	40	44	6,172	6,375	5,30	2,60	F
N°6	3,505	32	40	7,747	7,950	6,30	3,00	G
N°8	4,166	32	36	8,534	8,763	6,30	3,00	H
N°10	4,826	24	32	9,321	9,550	6,30	3,00	I
N°12	5,486	24	28	10,871	11,125	7,50	4,50	J
1/4	6,350	20	28	10,871	11,125	7,50	4,50	K
5/16	7,938	18	24	12,420	12,700	8,80	4,80	L
3/8	9,525	16	24	13,995	14,274	8,80	4,80	M
7/16	11,113	14	20	17,145	17,475	11,00	6,00	N
1/2	12,700	13	20	18,694	19,050	13,00	7,20	O
9/16	12,032	12	18	21,869	22,225	15,00	8,00	P
5/8	15,875	11	18	23,418	23,825	17,00	9,50	Q
3/4	19,050	10	16	27,635	28,575	21,00	12,00	R
7/8	22,225	9	14	32,232	33,324	22,00	12,50	S
1	25,400	8	12	36,830	38,100	24,00	13,50	T
1 1/8	28,575	7	12	41,427	42,875	25,00	14,00	U
1 1/4	31,750	7	12	46,024	47,701	29,50	16,00	V
1 3/8	34,925	6	12	50,647	52,374	32,00	17,00	W
1 1/2	38,100	6	12	55,245	57,150	35,00	18,50	X

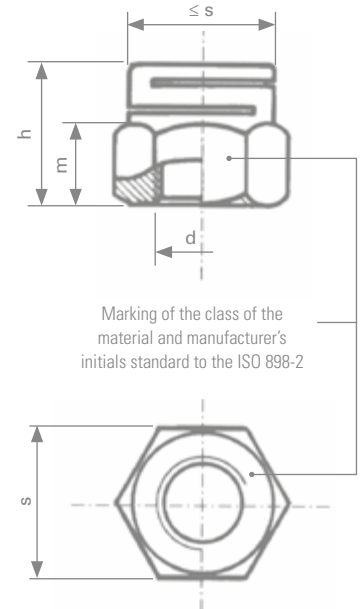

Quality class	Classification	Range of application
Grade 5/Grade B (class 8)	QV	Self color -50° C +300° C ⁽¹⁾
Grade 8/Grade C (class 10)	QK	
Stainless steel A2-70	ZE	Corrosive atmosphere -200° C +400° C ⁽¹⁾
Stainless steel A4-70	ZK	
Stainless steel A4-80	ZH	

Others: Brass - Bronze - Light alloy - Titanium...

⁽¹⁾ Values are only given as indication

Surface treatment (standard to ROHS requirements)			
Electrolytic coating (steel)	Yellow	ZJ	ISO 4042
	White LANTHANE®	ZL	ISO 4042
	White LANTHANE® Finish + Top coat	ZF	ISO 4042
Zinc lamellar (steel)			on request
Antigalling (stainless steel)	STANAL™400	ST	
	Sherardisation	SH	NF EN 13811
Self Color		BT	

Example of ordering code					
	Type	Diam x pitch	Class	Protection	
classification	ESL	N00UNC	QV	ZF	00
	ESL	ø 7/16" UNC	8	Zinc LANTHANE® Top coat	*

*Standard size